



DECT BIG meeting at Light + Building, Frankfurt

DECT Forum Buildings Interest Group members meet with building automation community at the world's leading fair for lighting and building services. Full report inside including video features.



Sennheiser case study: Aberdeen University chooses SpeechLine Digital Wireless.

Features:

VIDEO INTERVIEWS

- ▶ **VIDEO ROUNDTABLE: DSR CORP, R3 SOLUTIONS & STRATUM 9** - New companies join the push to take DECT NR+ to market
- ▶ **DECT FORUM'S AIR INITIATIVE BUILDS ON MERCI** - The Academia Industry Roundtable brings business and academia closer together
- ▶ **DECT TODAY INTERVIEW: OLIVER WITTIG, SNOM TECHNOLOGY** - From traditional cordless telephony to unified communications and beaconing

Plus:

DSR CORPORATION DEVELOPS NR+ STACK - Enabling scalable, secure and interoperable wireless connectivity for massive IoT and industrial automation

STRATUM 9 DECT NR+ GATEWAY - Gateway integrates DECT NR+ with existing Ethernet and industrial automation architectures

CONTACT DETAILS:

Publisher/Editor: Vince Holton
vholton@incisor.tv

ADVERTISING ENQUIRIES:

All enquiries – Roland Schmidt
secretariat@dect.org
Telephone: +49 89 5166 2456

DECT Today is distributed on a twice yearly basis to DECT Forum members and other interested parties.

Views expressed within are those of the editorial staff, the DECT Forum, and of DECT Forum member companies.

DECT Today, the DECT Forum, DECT Wireless and DECT NR+ logos are trademarks of the DECT Forum.

All other logos and trademarks are the property of the relevant companies.
©Copyright DECT Forum 2026.

SUBSCRIBE TO DECT Today

To subscribe free of charge to DECT Today magazine, please complete the form at our web site – [you can use this link here](#). You will receive DECT Today by email twice a year as an Adobe Acrobat file at the email address submitted.

If you like DECT Today, pass it on to friends and colleagues.

They too can subscribe, free of charge. Access the DECT Today archive any time [at this link](#).

Should you wish to stop receiving DECT Today, please use the unsubscribe option [at this link](#).

And follow the DECT Forum on LinkedIn, YouTube and Twitter/X too.



Click here



Click here



PRODUCED ON BEHALF OF THE DECT FORUM BY:
Click I.T. Limited

DECT TODAY ISSUE 25

New look for DECT Today and so much going on!

As we present the latest issue of DECT Today, it is a real pleasure to see just how much momentum continues to build across our community. DECT is evolving at pace, and DECT NR+ is very much at the heart of this journey.



Christian Schepke,
Chairman, DECT Forum

What is especially exciting is where this innovation is coming from. Strongly rooted in the Internet of Things and Industrial IoT, NR+ is proving itself as a robust, secure and scalable foundation for a wide range of applications. And while these industrial and IoT use cases are leading the way today, we are also seeing clear and very promising pathways into professional audio and unified communications in the future.

This issue, which features a new look that is in-synch with the new DECT Forum website, captures that spirit of progress and exploration.

Our video features bring together a NR+ roundtable with new entrants to the ecosystem – DSR Corporation, R3 Solutions and STRATUM 9 – who join Vince Holton to discuss opportunities across IoT and IIoT. We also hear from Andreas Wilzeck with an update on the DECT Forum AIR project, highlighting the growing collaboration between industry and academia that continues to energise our work.

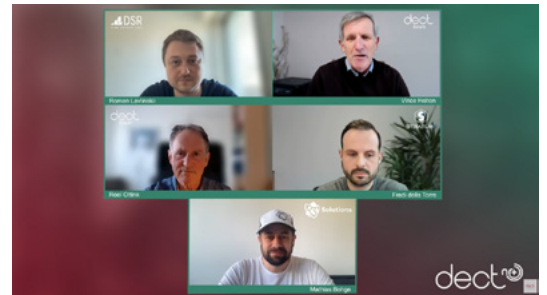

From the Professional Audio world, Oliver Wittig of Snom shares why DECT remains so central to their solutions, particularly when combined with beaconing technology to support complex deployments in medical and industrial environments.

We also look back at our presence at Light + Building in Frankfurt, where the DECT Forum’s Buildings Interest Group showcased its activities through a series of engaging presentations included in this issue.

Alongside the videos, our editorial features showcase further innovation across the ecosystem. STRATUM 9 introduces its NR+ Gateway, while DSR Corporation presents its NR+ stack designed to support scalable IoT, professional audio and industrial use cases. We also shine a spotlight on new companies joining the NR+ marketplace – another clear sign of the growing energy around the technology.



We are also pleased to include a Professional Audio case study from Sennheiser, showing how Aberdeen University is blending long-standing academic tradition with modern teaching facilities enabled by advanced wireless solutions.

Looking ahead, we provide information on upcoming events, including DECT World – our annual conference



taking place in November 2026. This remains a key moment for our community to come together, exchange ideas and help shape the future direction of DECT.



What continues to inspire me is the versatility and resilience of DECT technology. It has always delivered reliable, interference-free communication, and with NR+ we are extending that strength into entirely new domains.

A sincere thank you to all contributors, members and partners for your continued enthusiasm and support. It is your energy that drives this ecosystem forward.

I hope you enjoy this latest edition of DECT Today as much as we have enjoyed putting it together.

Christian Schepke
Chairman, DECT Forum

The DECT Forum welcomes new members

The DECT Forum continues to grow, welcoming an increasing number of companies from across the wireless ecosystem. This steady expansion reflects not only the Forum's momentum, but also the rising industry confidence in DECT NR+ technology.

In this feature, we are pleased to introduce the latest members of the DECT Forum, whose involvement highlights the growing interest in NR+ and its role in shaping the future of secure, scalable wireless connectivity. Notably, we are seeing an influx of organisations joining as Academic Members - a recently introduced category that is already gaining traction. Their participation brings valuable research insight and fosters closer collaboration between industry and academia.

Full membership:

BH Technologies



BH Technologies, an SME based in Grenoble and founded in 1998, is a major player in the intelligent management of public lighting and waste collection.

For more than twenty years, BH Technologies has been helping local authorities modernise their infrastructure. It's connected solutions help reduce costs and energy consumption. In addition, cities are improving the quality of their public services while accelerating their ecological transition. It helps them achieve their goals in two strategic markets: connected street lighting and optimised waste management.

R3 Solutions



R3 Solutions develops reliable wireless solutions for demanding industrial environments. These networks span three radio technologies: EchoRing, Wi-Fi and DECT NR+. As an active member of ETSI and the DECT Forum, R3 not only builds the products and solutions that industry will rely on tomorrow, but also contributes to shaping the NR+ standard itself. Made in Germany, proven on four continents.

STRATUM 9



STRATUM 9 is an end-to-end partner for DECT NR+ projects — industrial and beyond: licensing, co-development, gateways, and IoT/cloud platforms. Its specially developed MAC layer for NR+ maximises the efficiency of wireless communication and delivers minimal latency, outstanding scalability and reliable performance in demanding, densely networked IIoT environments.

Academic membership:

Friedrich-Alexander-Universität Erlangen-Nürnberg (FAU)



Established in 1743, FAU is one of the largest universities in Germany, with approximately 40,000 students, over 600 professors and around 6,700 members of staff.

University of Applied Sciences and Arts of Western Switzerland (HEIG-VD)



Located in the heart of Yverdon-les-Bains, HEIG-VD combines excellence and innovation through two key missions: teaching and research. Formed from the merger of the engineering (EIVD) and management (HEG-Vd) schools, it unites these two areas of expertise and actively promotes interdisciplinarity.

TH Deggendorf



The Deggendorf Institute of Technology is a public applied sciences university in Lower Bavaria, Germany. Founded in 1994, the institution offers undergraduate and graduate courses, and also doctoral programs in cooperation with Charles Sturt University.

Universidad Politecnica de Cartagena (UPTC)



The Polytechnic University of Cartagena, or UPCT, is a public university located in the Spanish city of Cartagena (Region of Murcia), with schools primarily focused on technology and business. It has been officially established since August 3, 1998.

Zurich University of Applied Sciences (ZHAW)



The Zurich University of Applied Sciences located in the city of Winterthur, with facilities in Zurich and Wädenswil, is one of the largest University of Applied Sciences in Switzerland.



6. The BIG team presented NR+ to the lighting and building automation industries.



12. The DECT NR+ Gateway is specifically designed for industrial environments.

Software is our craft.
Technology is our power.
Honesty is our creed.

Getting you to market is our mission.

9. DSR's NR+ stack is in development with a hardware-agnostic architecture, enabling migration between hardware platforms.

dect
forum

DECT Forum AIR – Academia Industry Roundtable

The DECT Forum AIR (Academia Industry Roundtable) is established to foster collaboration and cooperation between the industrial and academic communities, recognizing these partnerships as essential to the long term advancement and success of future DECT technologies.

The group serves as a bridge among diverse stakeholders and acts as a catalyst for innovation, resource sharing, and strategic development.

Objectives and Activities

14. How AIR is set to carry forward the momentum generated by MERCI, and why this matters for the future of DECT NR+.

DECT Forum video roundtable

Talking DECT NR+ with
DSR Corporation, R3 Solutions
and STRATUM 9

Shaping the Future of Secure
Wireless Communication

dect
forum

10. Providing a snapshot of how NR+ is being interpreted, implemented, and extended by companies operating at different layers of the wireless value chain.



18. Snom explains why DECT still matters in 2026.



20. SpeechLine Digital Wireless is a digital wireless microphone system for speech and lectures, designed and optimized for university and corporate use.



24. DECT World 2026 registration is now open! Two days that define the direction of DECT and NR+ for the year ahead — and beyond.

Features

6 VIDEO FEATURE: DECT FORUM EVENT AT LIGHT + BUILDING

When the global lighting and building automation industry gathered at Light + Building 2026, the DECT Forum's Buildings Interest Group staged a dedicated event to present NR+

9 DSR CORPORATION DEVELOPS DECT NR+ STACK

DSR's protocol stack is designed to enable scalable, secure and interoperable wireless connectivity for massive IoT and industrial automation

10 VIDEO ROUNDTABLE: WELCOMING FRESH PERSPECTIVES TO THE NR+ ECOSYSTEM

Our video roundtable features three recent additions to the DECT Forum - DSR Corporation, R3 Solutions and STRATUM 9

12 NR+ GATEWAY BRINGS DETERMINISTIC WIRELESS

STRATUM 9 has introduced industrially deployable radio hardware that integrates NR+ with existing Ethernet and industrial automation architectures

14 VIDEO INTERVIEW: THE AIR INITIATIVE BUILDS ON MERCI'S MOMENTUM

Andreas Wilzeck of Sennheiser explains the importance of close collaboration between academia and industry

18 VIDEO INTERVIEW: SNOM TECHNOLOGY INNOVATION SPOTLIGHT - BEACONING

We speak with Oliver Wittig, DECT Product & Professional Services Manager at Snom, to explore Unified Communications and beaconing

20 SENNHEISER CASE STUDY: OLD TRADITIONS COMBINED WITH MODERN TEACHING FACILITIES

The University of Aberdeen sought a reliable, high-quality microphone solution that could be quickly deployed. Sennheiser had the solution.

24 DECT World 2026 PROGRAMME GOES LIVE!

DECT World 2026 is the premier annual gathering for everyone who designs, deploys, or builds upon DECT and NR+ technology



DECT Forum at Light + Building: demonstrating the real-world power of DECT NR+

When the global lighting and building automation industry gathered in Frankfurt this March for Light + Building, the city once again became a focal point for the future of intelligent infrastructure. Known as one of the world's leading trade fairs for lighting, electrical engineering, and connected building systems, Light + Building brings together the people and technologies shaping how we will design, manage, and experience built environments in the decades ahead.

A timely industry gathering

Against this backdrop, the DECT Forum chose to host a dedicated public event in Frankfurt, running in parallel with the exhibition. The timing was deliberate: with thousands of professionals already focused on innovation in lighting and building services, it provided a unique opportunity to showcase the capabilities and momentum behind NR+ in a highly relevant context. The event was designed not as a standalone showcase, but as an embedded industry conversation—bringing together key stakeholders, practical demonstrations, and forward-looking discussions on large-scale IoT connectivity.

Four-part video series

The resulting video series, featured overleaf and on the DECT Forum YouTube channel, captures the breadth of that engagement. Across four recordings, the audience is taken from high-level strategic positioning through to technical insights, live industry debate, and market analysis.



Video 1: Christian Schepke, Chairman, DECT Forum.

The first video features an overview from Christian Schepke, Chairman of the DECT Forum. In his opening remarks, he reflects on the significance of the event and the importance of demonstrating NR+ in a real-world, multi-vendor environment. A key highlight of the Frankfurt showcase was the successful interoperability demonstration, where 80 devices from multiple manufacturers were connected reliably and efficiently on a single network. More than a technical milestone, the demonstration served as a practical validation of the NR+ vision: scalable, robust, and open connectivity for dense IoT and industrial deployments.

Building the NR+ ecosystem

The second video turns to the perspective of industry leadership within the building automation ecosystem. Bruno Vulcano of Legrand presents in his role as Chairman of the DECT Forum Buildings Interest Group. This group, formed with leading companies in the building automation sector, is focused on accelerating the evolution and adoption of NR+ standards in close cooperation with ETSI. Its objectives include supporting regulatory alignment, safeguarding and expanding spectrum availability, promoting NR+ adoption in large-scale IoT markets, ensuring multi-vendor interoperability through certification programmes, and fostering a truly global NR+ ecosystem. Bruno's presentation situates these goals within the broader context of accelerating digital transformation in buildings and the increasing convergence of IT and operational technology.

Industry panel discussion

The third video captures a dynamic panel discussion featuring representatives from the Buildings Interest Group, including participants from Legrand, Schneider Electric, Siemens, Nordic Semiconductor, Wirepas, Last Mile Semiconductor, and DSR Corporation. Moderated by Michelle Mindala-Freeman of SPG Advisory, the discussion explores the practical realities of deploying interoperable wireless systems at scale. Topics include ecosystem collaboration, certification and compliance pathways, spectrum considerations, and the role of open standards in enabling next-generation building automation and industrial IoT deployments.

Market perspective from BSRIA

The fourth and final video features a keynote presentation by Jeremy Towler of industry research organisation BSRIA. His analysis provides an external market perspective on building automation trends, including demand drivers, adoption barriers, and the evolving requirements of smart building stakeholders. The keynote helped contextualise NR+ within broader industry trajectories, highlighting where wireless innovation is most urgently needed and how new standards can align with market realities.



Keynote presentation by Jeremy Towler, BSRIA.

A cohesive industry narrative

Taken together, the four videos present a coherent narrative: from vision, to standards development, to multi-vendor collaboration, and finally to independent market validation. They demonstrate not only the technical maturity of NR+, but also the strength of the ecosystem forming around it.

Networking, discussion and industry momentum



Beyond the formal presentations and recordings, the Frankfurt event itself reflected a broader industry shift. Attendance was strong, and the atmosphere throughout the day remained consistently engaged and interactive. Once the formal sessions concluded, participants transitioned into an informal but highly productive networking session. Here, attendees had the opportunity to engage directly with speakers, observe the live demonstration environment, and exchange views on deployment challenges and opportunities. These conversations underscored a central theme of the event: that the future of large-scale IoT connectivity will be shaped not only by standards and silicon, but by sustained collaboration across the entire value chain.

Positioning NR+ for the future

For the DECT Forum, the Frankfurt event represented an important milestone in continuing to position NR+ as a credible, scalable, and industry-backed solution for demanding IoT and industrial applications. By aligning with Light + Building and engaging directly with the building automation community, the Forum was able to demonstrate both technical capability and ecosystem readiness in a single, compelling setting.



Watch the series

As this video series is released through DECT Today and the DECT Forum's digital channels, it offers readers and viewers a chance to revisit the discussions, explore the technical depth of the presentations, and gain insight into the collaborative momentum driving the NR+ ecosystem forward.

Click on the screens to watch each of the individual movies.

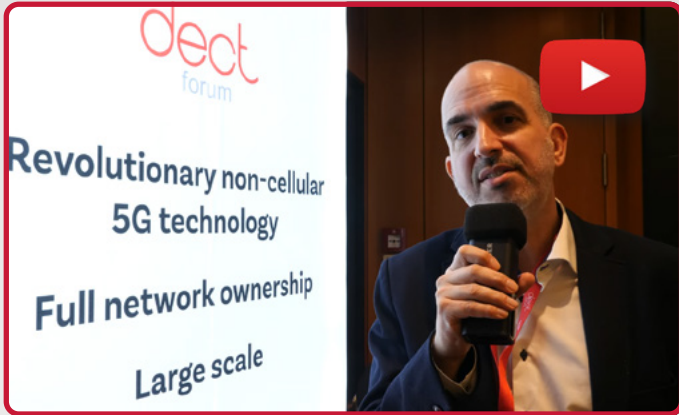

DECT Forum Chairman's overview of the BIG event



Bruno Vulcano of Legrand presents in his role as Chairman of the DECT Forum Buildings Interest Group



At the DECT Forum's event at Light + Building we had an assembly of some of the most significant individuals and companies that are driving NR+ forward today



Jeremy Towler of BSRIA provided a comprehensive overview of the Building Automation marketplace



Visit the DECT Forum YouTube channel

DSR Corporation developing DECT NR+ stack to support scalable IoT, Pro-Audio and Industrial use-cases

DSR Corporation (DSR), a developer of embedded and wireless software development, has begun development of a DECT NR+ protocol stack designed to enable scalable, secure and interoperable wireless connectivity for massive IoT and industrial automation deployments.

DSR has more than twenty years of experience in wireless protocol stack development, including development of the ZBOSS Zigbee PRO stack and co-founding the ZBOSS Open Initiative (ZOI), a collaborative member-source community that brings together semiconductor vendors, device makers, and other ecosystem participants to work on a common Zigbee PRO software platform.

“We see NR+ as enabling a new class of wireless deployments that require scalability, ultra-low latency, and interoperability,” said Anatoli Pechkov, CEO of DSR Corporation. “With decades of experience in wireless protocol stack development, we are building the stack to support demanding use cases in building automation, Pro-Audio, and industrial environments, while establishing a community model that enables easy adoption.”

Christian Schepke, Chairman of the DECT Forum added: “From an ecosystem perspective, this type of stack development is critical to accelerating adoption of NR+ as new member of the DECT family of standards. We welcome DSR’s work providing a strong technical foundation for companies looking to develop interoperable, next-generation wireless solutions.”

The NR+ stack is in development with a hardware-agnostic architecture, enabling migration between hardware platforms with minimal effort. The architecture also allows for flexible distribution of stack layers between the network processor and the host processor, supporting different system designs and deployment requirements. Additionally DSR is establishing an NR+ network simulation platform to accelerate protocol development and support rapid prototyping and validation of large-scale deployments.

The stack is designed as a multipurpose solution, configurable

Software is our craft.
Technology is our power.
Honesty is our creed.

Getting you to market is our mission.



to support multiple use cases, including Building Automation, Pro-Audio, and Industrial applications with ultra-low latency.

As part of its long-term goal, DSR is designing the NR+ stack to support large-scale deployments, including configurable network topologies such as cluster tree, mesh, and star. The stack is intended to support IPv6 networks comprising thousands of devices, with security aligned with the latest EU regulatory standards. The stack design and architecture are well positioned to accommodate transport-layer support for protocols such as Matter and KNX.

For Pro-Audio and other ultra-low latency applications, the NR+ stack is designed to enable streaming with less than three milliseconds of network latency for devices operating in star topology networks, along with resistance to carrier radio issues through smart carrier sensing and transmission mode selection algorithms.

DSR told DECT Today that it intends to advance the NR+ stack through an adopter-driven community model modeled on the ZBOSS Open Initiative, fostering collaboration on a unified platform that accelerates development, lowers R&D investment, and improves product interoperability. The ZBOSS Open Initiative is a market-proven member-source model successfully operated by DSR since 2020, with dozens of active members. Participation in the NR+ community will follow this proven structure through annual membership, with fees reinvested into continued stack development and technical support. Community members will receive access to the source code and licensing rights for stack usage with no royalties or per-copy fees.

More information about DSR Corporation:

<https://en.dsr-corporation.com/>

New voices, shared momentum: welcoming fresh perspectives to the DECT NR+ ecosystem

In a rapidly evolving wireless landscape, the arrival of new participants is often the clearest signal that a technology has moved beyond promise into real momentum. For the DECT Forum, that moment is now unfolding around NR+.

In this issue of DECT Today, we present a video roundtable featuring three recent additions to the Forum—R3 Solutions, STRATUM 9, and DSR Corporation—each bringing distinct expertise and a strong commitment to advancing this next-generation standard.

Hosted by Vince Holton, the discussion goes beyond introductions. It offers a snapshot of how NR+ is being interpreted, implemented, and extended by companies operating across different layers of the wireless value chain. From protocol stack development and MAC-layer innovation to full-system integration and industrial deployment, a shared message emerges: NR+ is not just another wireless option—it is a platform with the potential to reshape connectivity in IoT and Industrial IoT environments.

A technology reaching critical mass

NR+ is the first 5G technology to operate in unlicensed spectrum, combining the determinism and reliability required by industrial applications with the scalability expected in Massive IoT deployments. For engineers and system architects, this combination is especially compelling. It delivers both performance and flexibility, enabling deployments without the regulatory and cost constraints associated with licensed spectrum.

What makes this moment particularly significant is the growing ecosystem around the technology. The presence of new member companies actively investing in development signals a transition from standardization to implementation. Each of the roundtable participants represents a different entry point into this ecosystem, collectively highlighting its breadth and maturity.

MEET THE PARTICIPANTS

Building the foundations: DSR Corporation



With more than two decades of experience in wireless software development, DSR Corporation enters the NR+ space with a clear focus on building a robust, scalable, and interoperable protocol stack.

DSR's background in ecosystem-driven technologies, including Zigbee PRO, informs its approach. The company is developing a hardware-agnostic stack designed to support diverse applications, from building automation to industrial systems and professional audio.



Flexibility is central to its architecture. By allowing stack layers to be distributed across network and host processors, DSR enables system designers to tailor implementations to specific performance and cost requirements—an important consideration in industrial IoT, where deployments vary widely.

The company is also investing in tooling, including a network simulation platform that accelerates development and supports rapid prototyping of large-scale systems. This reduces time-to-market and lowers implementation risk.

As highlighted in the roundtable, DSR's role extends beyond stack development. By providing tools and frameworks, it helps lower the barrier to entry for companies adopting NR+.

Innovation at the MAC layer: R3 Solutions



R3 Solutions brings deep expertise at one of the most critical layers of wireless communication: the Medium Access Control (MAC) layer.

Originating from academic research at RWTH Aachen, the company's work is grounded in a strong theoretical foundation. Its proprietary EchoRing technology reflects years of modelling and experimentation focused on achieving high-availability, real-time wireless communication.

This positions R3 strongly within the NR+ ecosystem. Working at the firmware level, the company collaborates with silicon vendors such as Nordic Semiconductor to implement and optimize MAC-layer functionality. This close-to-hardware approach enables fine-grained customization and performance tuning, which is essential for demanding industrial use cases.

R3 also contributes to standardization, particularly in defining industrial automation profiles within ETSI DECT. By shaping how NR+ behaves in real-world scenarios, the company is influencing both implementation and evolution of the standard.

Its involvement in collaborative research initiatives, including the MERCI project, has already produced tangible results, such as demonstrations of autonomous mobile robots using NR+ for wireless safety signalling.

Looking ahead, the planned release of its EDGE D device in 2026 marks a shift from research to productisation—a critical step in bringing the technology to market.

From architecture to deployment: STRATUM 9



STRATUM 9

STRATUM 9 positions itself as a full-spectrum engineering partner, bridging the gap

between theory and deployment.

Its work focuses on development and optimization of the NR+ stack, with particular emphasis on MAC-layer performance. The company highlights three priorities: low latency and determinism, quality of service, and robustness under industrial conditions—key requirements for real-time control and mission-critical communications.

What distinguishes STRATUM 9 is its holistic approach. Rather than focusing solely on software or hardware, it offers an integrated portfolio that includes gateway solutions, custom radio modules, backend integration, and consulting services spanning planning, prototyping, and certification.

This end-to-end capability is especially valuable for industrial customers, who often require complete solutions rather than individual components. It also supports faster transitions from proof-of-concept to production.

To facilitate this, STRATUM 9 has developed a NR+ Starter Kit, providing a production-oriented evaluation platform. This reflects a broader ecosystem trend toward tools that make experimentation and validation more accessible.

Converging perspectives, shared goals

Despite their different areas of focus, several common themes emerged across the discussion.

Determinism and reliability were consistently identified as core requirements. In industrial environments, wireless systems must deliver predictable, low-latency performance, often replacing wired connections. DECT NR+ is widely seen as well positioned to meet these demands.

Flexibility across use cases is another priority. Applications range from building automation to intralogistics and professional audio, requiring adaptable configurations that can meet diverse needs.

Collaboration also plays a central role. All three companies emphasized partnerships with silicon vendors, research institutions, and other ecosystem players. This aligns closely with the DECT Forum's mission of fostering cooperation.

Click on the movie screen here to watch the video interview with Roman Lavlinskii, Roel Ottink, Fredi della Torre and Mathias Bohge.

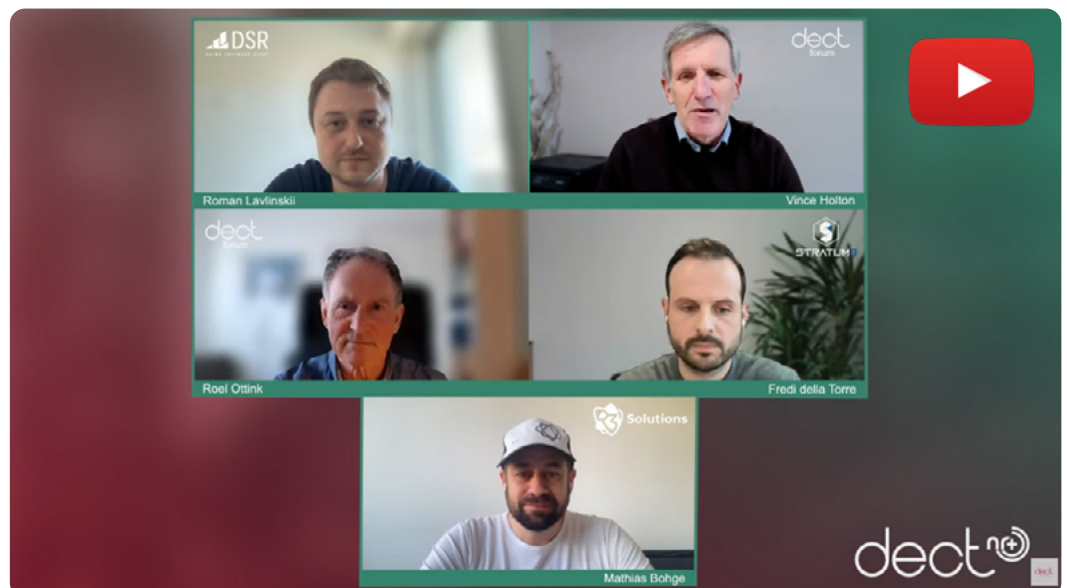

Finally, there is a strong focus on accelerating market readiness. Through simulation tools, starter kits, and product development, each company is working to bring NR+ solutions to market more quickly.

Why new entrants matter

The addition of R3 Solutions, STRATUM 9, and DSR Corporation is significant not only for their individual contributions, but for what they represent collectively.

New entrants introduce fresh perspectives, challenge assumptions, and expand the range of possible solutions. Their investment in development and ecosystem participation also signals confidence in the technology.

For existing members, this creates new opportunities for collaboration and innovation. For potential adopters, it provides reassurance that the ecosystem is growing and maturing.

Looking ahead

As NR+ continues to evolve, ongoing dialogue within the ecosystem will be essential. The video roundtable featured in this issue of DECT Today illustrates how these conversations can bring together different viewpoints, share experiences, and identify common challenges.

The transition from standard to widespread adoption requires contributions at every level—from chipset design and protocol development to system integration and deployment. It also depends on a willingness to collaborate, experiment, and iterate.

An invitation to engage

As the DECT Forum community continues to expand, organizations across the industry are encouraged to explore the opportunities presented by NR+.

The technology is ready, and the ecosystem is gaining momentum. As this roundtable shows, there is ample room for new ideas and contributions.

We invite you to watch the full discussion and hear directly from the participants. It offers valuable insight into how organizations can play a role in shaping the future of wireless connectivity in IoT and Industrial IoT.

The momentum is building—and this is just the beginning.



STRATUM 9's DECT NR+ gateway brings deterministic wireless into industrial automation

With its DECT NR+ Gateway, STRATUM 9 introduces the first industrially deployable radio hardware that integrates NR+ with existing Ethernet and industrial automation architectures, making deterministic wireless communication usable in mobile industrial systems.

“By making NR+ available for industrial use, we are overcoming fundamental limitations of wireless communication in industrial environments,” says Alfred della Torre Jr., co-founder and managing director of STRATUM 9.



Alfred (Fred) della Torre & Hubert Feurstein, co-founders, STRATUM 9.

Chief Technical Officer and co-founder Hubert Feurstein adds: “For the first time, we have achieved guaranteed deterministic real-time wireless communication in the public spectrum that can withstand the high demands of highly dynamic industrial processes.”

The NR+ Gateway is specifically designed for industrial environments and can be used for both time-critical and sensor-based applications. A key advantage is that the same hardware can be configured either as a fixed termination point (FT) or as a portable termination point (PT), supporting stacking several FTs into a higher-capacity “Super FT” when bandwidth demand increases. That simplifies rollout, spare-part handling and system design, while also giving OEMs and system integrators a flexible building block for different wireless topologies.

Scheduled access makes the difference

For industrial users, the most important aspect of the gateway is its deterministic communication model. The gateway can run either STRATUM 9's own Scheduled Access MAC layer or the Nordic Semiconductor MAC layer. In the scheduled model, airtime is centrally organised and time slots are explicitly assigned, which removes channel contention and keeps communication behaviour predictable even when several mobile nodes are active in parallel. By contrast, the Nordic MAC layer follows a random-access approach that is entirely valid for many NR+ applications, especially event-driven sensors and metering, but is not capable to provide the same level of deterministic behaviour for motion-related, time-critical automation.

In mobile systems, the real challenge is maintaining stable, predictable communication while AGVs, carriers or moving machine elements remain in operation and multiple participants communicate in parallel. This is where STRATUM 9's NR+ Gateway provides clear value.

In combination with deterministic control, it enables seamless handovers during ongoing communication, allowing devices to move between base stations without interrupting communication flow. Handover behaviour is often where industrial wireless ambitions break down. A wireless link may look excellent in a static demo, yet become unusable once a

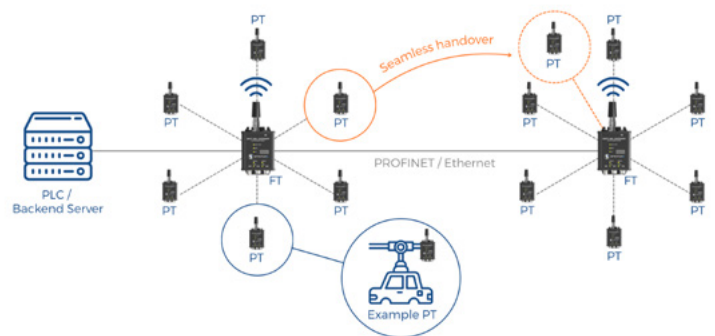

STRATUM 9's DECT NR+ Gateway architecture: Star topology via NR+ with seamless handover.

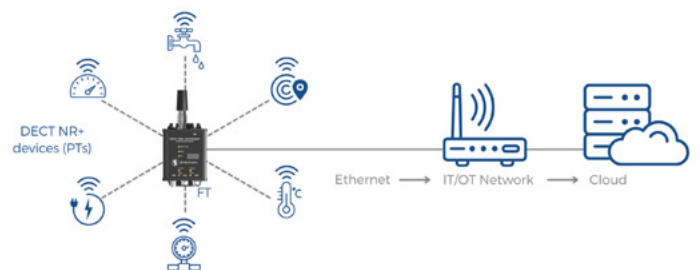

The NR+ Gateway as a wireless Ethernet bridge for multiple mobile (battery-powered) NR+ devices.

robot, shuttle or conveyor-borne participant crosses coverage boundaries under active control traffic. STRATUM 9's answer is a scheduled star topology designed for mobility, and in the current configuration one FT can manage up to 16 mobile participants.

Technical Data

Data Interface:	2x LAN, 1x CAN/Pwr
Connectors:	Vibration-proof M12 Ethernet ports
Supply Voltage:	24 V DC
Range:	Up to 1 km (line-of-sight)
Start-up Time:	< 5 s
Dimensions (H x B x D):	192 x 87 x 32 mm
Housing:	Aluminum, IP54

Wireless PROFINET and PROFISAFE

For many automation engineers, a very compelling aspect of the gateway will be the transparent handling of industrial traffic. PROFINET and PROFISAFE are transferred fully unchanged to mobile participants and devices. No protocol conversion is required, and existing architectures can remain intact.

This creates a clear advantage in brownfield and retrofit scenarios. Mobile systems can be integrated into existing PLC-based environments without adding unnecessary protocol layers or redesigning the control structure. However, the gateway itself is not a safety device. It simply acts as a transparent communications element (black channel) within the system architecture and directly passes through the safety-critical data.

That distinction makes the product especially attractive for users who want to bring wireless mobility into established industrial networks without disrupting proven automation concepts.



The NR+ Gateway enables wireless, unmodified PROFINET/PROFISAFE transmission to mobile applications.

Built for large moving systems

The gateway is well suited to applications such as sorting systems, electric monorail systems and other conveyor-based environments. In these installations, many mobile participants need to communicate simultaneously and reliably with a central infrastructure. Metallic surroundings, reflections, large expansions and parallel traffic can make conventional radio technologies difficult to plan and unstable in daily operation.

NR+ addresses this challenge with its dedicated frequency band, deterministic communication mechanisms and a robust OFDM modulation scheme that offers significant advantages in terms of multipath propagation (echoes). With its combination of scheduled access, seamless handover, transparent PROFINET transmission, and flexible deployment roles, the NR+ Gateway is a significant infrastructure building block for the next generation of mobile industrial automation.

Industry-proven technology

An initial deployment example is STRATUM 9's collaboration with component manufacturer DETO Automation and the ROFA Group, a specialist in conveyor technology, who use the wireless module for applications in intralogistics and for overhead conveyor systems in the automotive sector.

As Martin Wolf, Managing Director of DETO Automation Germany, explains: "With NR+, we now have a communication solution that, for the first time, fully meets the current needs of industrial facilities. There is a high demand for facility retrofits, as well as a need to implement them during ongoing operations without downtime. We can meet precisely this requirement for our customers with the transparent PROFINET transmission developed by STRATUM 9."

A strong step for industrial NR+

With this launch, STRATUM 9 is expanding its NR+ portfolio with a hardware component that is ready for immediate use in evaluation, integration and rollout. The DECT NR+ Gateway is available now and enquiries can be made directly to STRATUM 9.

In addition to the gateway, STRATUM 9 offers solutions for custom NR+ implementation at different levels. These include the licensable NR+ software stack for developing proprietary products, a NR+ starter kit for rapid evaluation and prototyping, and a complete development package for custom end-to-end solutions comprising hardware, firmware and cloud backend services. This enables companies to receive support tailored to their needs, from early-stage technology validation through to full-scale industrial product integration.

"As industrial environments continue to evolve, NR+ will play a crucial role in enabling smarter facilities, more agile logistics and safer operational processes," said Alfred della Torre Jr. "With our gateway, we are creating a concrete, industrially viable foundation for this."

For further information, please follow this link: <https://st9.at/dectnr-gateway>

About STRATUM 9

STRATUM 9, based in Kufstein, Austria, develops embedded systems, IoT solutions and industrial wireless communication technologies based on NR+. The company combines hardware, firmware and system integration expertise to support industrial customers from evaluation through to deployment. Since 2026, STRATUM 9 has been a full member of the DECT Forum and is also a Nordic Solution Partner.

Bridging innovation: how the DECT Forum's AIR initiative builds on MERCI's momentum

As wireless technologies evolve to meet the growing demands of the Internet of Things (IoT), Industrial IoT (IIoT), and Professional Audio applications, collaboration between academia and industry is becoming increasingly important.

Against this backdrop, the DECT Forum's Academia Industry Roundtable (AIR) initiative builds directly on the success of MERCI, one of the most ambitious recent research programmes in the DECT ecosystem.

In this issue of DECT Today, an accompanying video interview with Andreas Wilzeck of Sennheiser explores how AIR will carry forward MERCI's momentum - and why this matters for the future of DECT NR+.

From MERCI to AIR

AIR is the natural successor to MERCI (Media and Event Production via Resilient Communication on IoT Infrastructure), a Franco-German research initiative focused on exploring the full potential of DECT-2020 NR (DECT NR+).

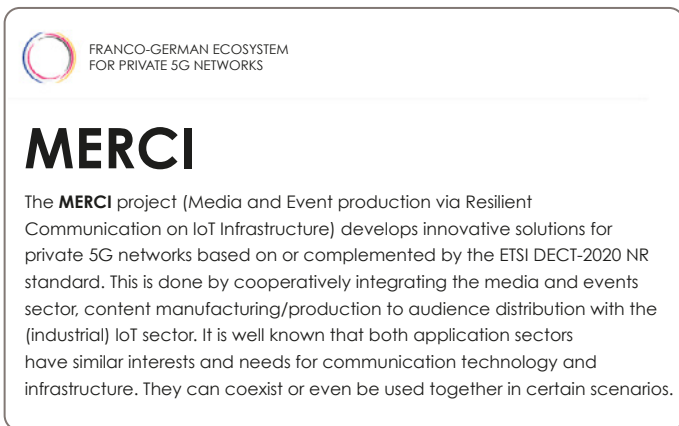

FRANCO-GERMAN ECOSYSTEM FOR PRIVATE 5G NETWORKS

MERCI

The **MERCI** project (Media and Event production via Resilient Communication on IoT Infrastructure) develops innovative solutions for private 5G networks based on or complemented by the ETSI DECT-2020 NR standard. This is done by cooperatively integrating the media and events sector, content manufacturing/production to audience distribution with the (industrial) IoT sector. It is well known that both application sectors have similar interests and needs for communication technology and infrastructure. They can coexist or even be used together in certain scenarios.

The project brought together industry and academia, including Sennheiser, ATEME, RFmondial, Wirepas, Leibniz University Hannover, and Ostfalia University of Applied Sciences. Its goal was to develop solutions for private 5G networks based on, or complemented by, NR+, while connecting the needs of media production and industrial IoT.

Although these sectors differ in application, they share core requirements: reliability, low latency, and consistent performance. MERCI used this common ground to drive cross-sector innovation.



DECT Forum AIR -Academia Industry Roundtable

The DECT Forum AIR (Academia Industry Roundtable) is established to foster collaboration and cooperation between the industrial and academic communities, recognizing these partnerships as essential to the long term advancement and success of future DECT technologies.

The group serves as a bridge among diverse stakeholders and acts as a catalyst for innovation, resource sharing, and strategic development.

Objectives and Activities

- Connect representatives from industry, research institutions, and universities.
- Exchange insights on research, technology trends, and study needs.
- Share information on funding opportunities.
- Initiate and support collaborative research projects and joint initiatives.
- Promote visibility of research through publications, events, and standardization activities.
- Facilitate partnerships to strengthen the impact of DECT community efforts.

Participation

The DECT Forum AIR is open to individuals with planned or ongoing involvement in collaborative and publicly co-funded research related to DECT technologies.

A breakthrough for NR+

Launched in 2023, MERCI reached an early milestone with the availability of chipsets and development boards from Nordic Semiconductor. This enabled rapid progress from concept to practical implementation.

Over the following two years, the project delivered a series of demonstrations showcasing NR+ in real-world scenarios. At its final workshop in July 2025, hosted at Sennheiser, these included automated guided vehicles, advanced mesh networking, and the first live MPEG-H object-based audio transmission over NR+.

A full concert setup further demonstrated the technology's ability to meet demanding requirements for latency, reliability, and audio quality—highlighting its relevance for professional audio alongside industrial use cases.

Rethinking private 5G networks

MERCI also challenged conventional approaches to private 5G. Traditional 3GPP-based solutions can involve high costs, complex deployment models, and regulatory barriers that limit adoption.

NR+ offers a different approach. As a non-cellular 5G technology, it enables high-performance wireless communication with greater flexibility and lower complexity. It also allows organisations to deploy and manage their own networks more directly, helping align IT and operational technology requirements.

This makes private 5G networks more accessible, particularly in dense or specialised environments, without the economic and operational constraints often associated with cellular systems.

Academic collaboration in action

Academic partners were central to MERCI's success, contributing research, prototypes, and demonstrators.

Ostfalia University of Applied Sciences explored the digitisation of spectrum allocation, demonstrating how users could request frequencies via a simple interface and receive rapid feedback from regulatory authorities - streamlining processes for live events and other dynamic environments.

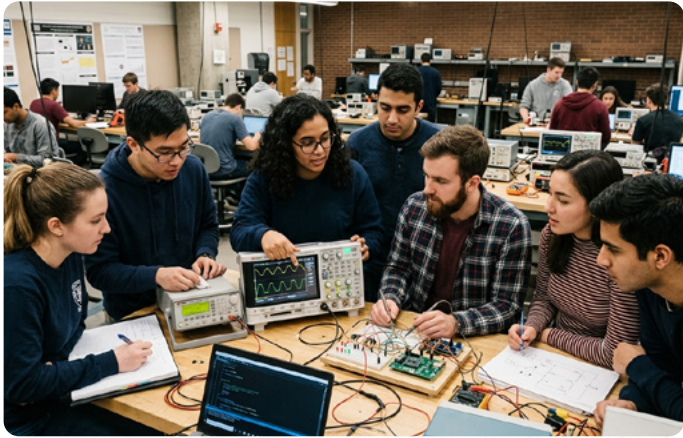

The Technical University of Cartagena developed compact NR+ hardware and explored mesh networking, including a vibration sensor for remote monitoring, illustrating applications in Industrial IoT and smart metering.

Leibniz University Hannover demonstrated a software-defined radio operating in the 3.8–4.2 GHz range, showing that NR+ can extend beyond its traditional 1.9 GHz band - an important consideration as Europe evaluates spectrum options for private 5G.

Together, these contributions highlight the role of academic research in expanding both the capabilities and application range of NR+.

AIR: sustaining and scaling collaboration

With MERCI complete, AIR has been established to maintain and extend its momentum.

Rather than focusing on a single initiative, AIR provides a framework for ongoing collaboration between industry and academia. It connects companies, research institutions, and universities, enabling knowledge exchange, joint projects, and alignment on emerging technology trends.

The initiative also supports collaborative research by sharing funding opportunities and encouraging partnerships, while promoting results through publications, events, and standardisation activities.

In this way, AIR shifts the focus from a successful project to a sustained model for innovation.

A platform for the future of DECT

For Andreas Wilzeck - MERCI consortium lead and a driving force behind AIR - the initiative represents a strategic step forward. In the video interview, Andreas reflects on more than a decade of research into wireless technologies for Professional Audio, noting that earlier approaches often proved unviable. MERCI, by contrast, demonstrated that NR+ can meet both technical and economic requirements across multiple use cases.

This validation opens new opportunities for companies such as Sennheiser to expand product portfolios and develop new applications based on the technology.

AIR now provides the structure to continue that progress through collaboration and shared development.



Andreas Wilzeck, Sennheiser.

An open invitation to collaborate

AIR is open to organisations and individuals involved in collaborative, publicly funded research related to DECT technologies, creating opportunities for broader participation across the ecosystem.

Looking ahead, and as demand grows for reliable, flexible, and cost-effective wireless connectivity, NR+ is well positioned to play an important role. The transition from MERCI to AIR reflects a move toward sustained collaboration - linking research with real-world deployment and enabling continued innovation.

The video interview with Andreas Wilzeck offers both a reflection on MERCI's achievements and a perspective on what comes next.

Click on the movie screen below to watch the video interview with Andreas Wilzeck.

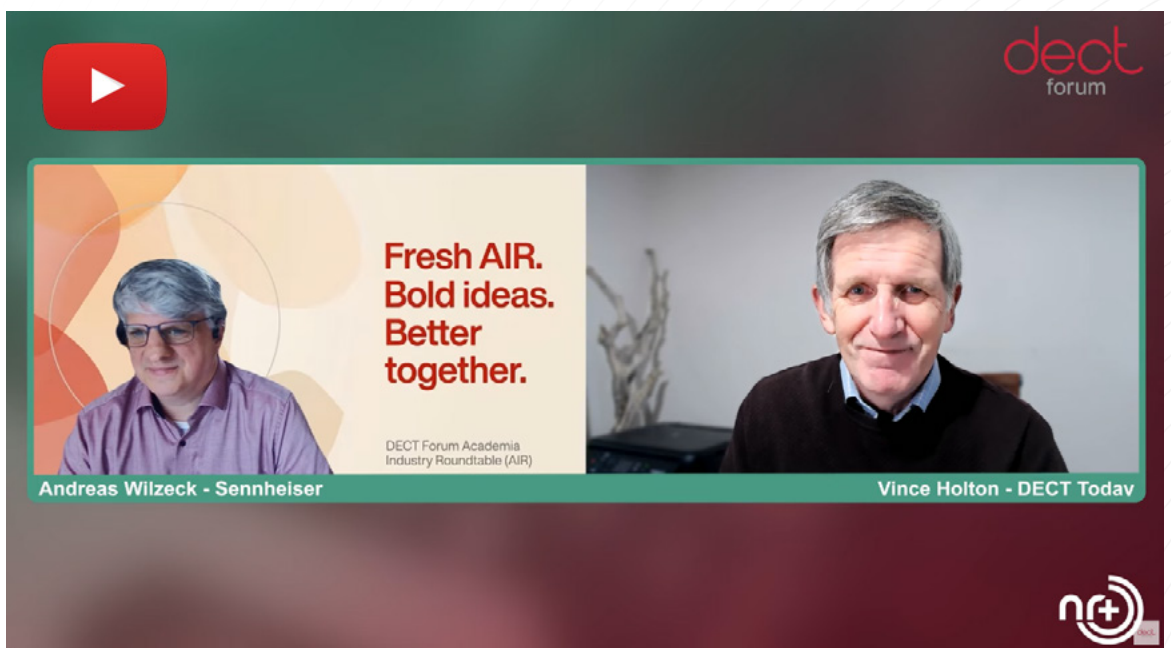

Companies developing around DECT NR+

We are pleased to put the spotlight on the following companies who are each involved in development based around NR+.

Each company has provided the following information about its activities.

CTHINGS.CO - delivering reliable, actionable intelligence from highly distributed edge environments

CTHINGS.CO[®]
EDGE IOT SOLUTIONS

CTHINGS.CO develops advanced software, hardware, and hybrid cloud solutions to support scalable edge AI and IoT deployments across distributed environments.

At the core of its portfolio is Orchestra, a platform designed to simplify the management of Linux-based edge devices at scale. Through secure remote monitoring, over-the-air (OTA) updates, hardened OS, and streamlined lifecycle management, Orchestra enables organizations to operate distributed systems with greater efficiency, security, and control.

To support these deployments, CTHINGS.CO provides certified hardware, such as Edge IoT Gateways and Edge IoT Connectivity Cards that simplify the integration of modern wireless technologies into new and existing systems. A dedicated programming jig further enables customers to develop and deploy custom firmware tailored to specific application requirements.

As industries adopt more decentralized architectures, NR+ is emerging as a key enabler of resilient, low-power connectivity. CTHINGS.CO supports this evolution through the modular Connectivity Cards based on Nordic Semiconductor's nRF9161 and nRF9151 chipsets, available in M.2 and mPCIe form factors. The Connectivity Cards are supplied with Wirepas 5G Mesh firmware to provide scalable networking and enable seamless and secure integration of NR+ into edge devices, gateways, and industrial systems.

By combining interoperable hardware with Orchestra's centralized orchestration capabilities, CTHINGS.CO delivers a unified framework for managing complex edge deployments. This approach enables easier provisioning, secure continuous updates, and the flexibility to scale distributed networks in line with evolving industry and regulatory requirements.

[CTHINGS.CO](https://www.cthings.co)

FL Semiconductor: pioneering the future of massive IoT with NR+

FLSEMI[®]

Founded in 2025 in Florida, FL Semiconductor LLC is a technology firm specializing in advanced wireless solutions integrated with self-powering technology. Leveraging over two decades of expertise in Bluetooth and wireless stacks, the company is now at the forefront of the 5G NR+ revolution. We focus on bridging the gap between complex industrial requirements and seamless connectivity for high-density sensing, smart cities, and mission-critical infrastructure.

Our commitment to NR+ stems from its unique decentralized, self-healing mesh architecture. By developing specialized MAC layer implementations and ETSI-compliant solutions, FL Semiconductor is empowering "zero-maintenance" endpoints—integrating energy harvesting with NR+ to serve industrial and public sectors in both the U.S. and Taiwan, alongside our Taiwan-based sister company, BANFi Semiconductor Co., Ltd.

We have already hit the ground running. In January 2026, we successfully deployed NR+ solutions for sensing uplinks in a semiconductor foundry and a government freeway infrastructure project. We are now actively exploring advanced control applications utilizing the full suite of channel capabilities, including PCH, DCH, and RACH. We believe NR+ is the essential link for truly scalable, interference-free massive IoT, operating across Sub-GHz to 1.9 GHz bands and utilizing FTDMA slots with dynamic MCS to achieve unprecedented network efficiency and reliability.

www.flsemi.us

Ignion and DECT NR+: enabling flexible RF integration for IoT devices

Integrating NR+ into connected devices introduces familiar challenges: limited space, multiple radios, and increased RF validation complexity. Ignion addresses this through its Virtual Antenna® technology, a non-resonant multi-band approach designed to simplify antenna integration in compact wireless devices. For manufacturers developing smart meters, smart building systems, and industrial IoT nodes, this provides a more predictable way to incorporate NR+ without extensive antenna redesign.

As NR+ continues to gain momentum as a standard for scalable, local IoT networks, Ignion's technology aligns with the needs of device makers looking to combine multiple wireless protocols within a single design. Its antenna booster components and Oxion™, an AI-powered antenna integration platform, support engineers in evaluating antenna placement, tuning performance, and adapting designs across product variants. Beyond early-stage design, Ignion also supports the full RF integration process, from feasibility and tuning through to pre-certification and debugging.

By reducing integration complexity and enabling more flexible hardware design, Ignion contributes to the broader NR+ ecosystem, helping accelerate adoption across applications such as smart metering, building automation, and industrial connectivity.

Engineers who want to explore the options are invited to use www.oxion.ai to embed NR+ in existing or new designs.



Embedded World 2026 Strong momentum and growing visibility for NR+

Embedded World 2026, held in Nuremberg from March 10 to 12, proved to be a highly successful outing, reinforcing the growing market interest in NR+ technology. With a 21 square metre stand open on two sides in Hall 3 (M2M), the team welcomed a record number of visitors, collected over 100 contacts — roughly 20% more than in 2025 — and generated a pipeline of high-potential leads across key industrial sectors.

Booth & on-site presence

The stand was strategically located in Hall 3 M2M, a dedicated area for machine-to-machine and connectivity technologies. The open two-sided configuration encouraged foot traffic and spontaneous visitor engagement throughout the three days. Marketing collateral and informational materials were distributed to all interested visitors, supporting both awareness and in-depth technical discussions.

Key themes & visitor interest

Conversations at the booth centred on several compelling NR+ differentiators. Visitors consistently highlighted the following topics as their primary areas of interest:

- Network scalability — the ability to grow deployments without infrastructure bottlenecks
- License-free spectrum — eliminating ongoing spectrum costs and regulatory complexity
- Energy efficiency and battery life — critical for Industrial IoT and remote sensor applications

Frequent questions also arose around ecosystem readiness, deployment pathways, and semiconductor availability — areas that reflect the market's eagerness to move from evaluation to real-world implementation. The volume and depth of these discussions are a clear indicator of NR+'s growing visibility compared to previous years.

Contacts & follow-up strategy

Follow-up communications are planned with all collected contacts, with particular focus on the highest-potential leads identified during on-site conversations.

Looking ahead to 2027

The booth size proved adequate for this year's needs, though the option of organising an umbrella stand together with member organisations is worth exploring as a way to increase shared presence and reduce individual costs.

Overall, Embedded World 2026 confirmed that NR+ is gaining meaningful traction in the embedded and industrial connectivity market.

Please watch our event section on the website for updates: <https://www.dect.org/resources/>

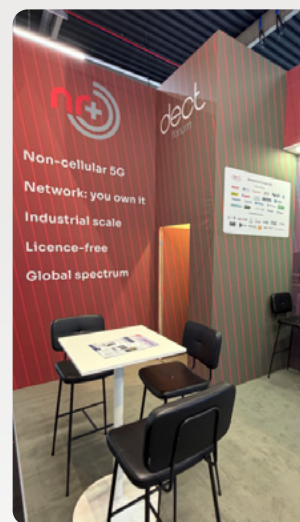

Snom Technology

As wireless communication technologies continue to evolve, the demand for solutions that combine reliability, scalability, and interoperability has never been greater.

In the Unified Communications (UC) and Professional Audio sectors in particular, developers and system architects are under increasing pressure to deliver platforms that perform consistently in complex and often congested RF environments. Against this backdrop, DECT has maintained a very strong position as a technology of significant interest - valued not only for its proven track record in voice, but also for its adaptability to new and emerging use cases.

Snom's role in the DECT ecosystem

One company that has consistently recognised and championed this potential is Snom Technology. A long-standing contributor to the DECT ecosystem and an active member of the DECT Forum, Snom has played a key role in advancing the use of DECT in enterprise communications. With roots in IP telephony and a strong focus on professional-grade solutions, the company has built a reputation for delivering robust, standards-based products designed to meet the needs of demanding business environments.

Meet the expert: Oliver Wittig

In this edition's video feature, we speak with Oliver Wittig, DECT Product & Professional Services Manager at Snom, to explore both the company's journey and its current direction. The conversation begins with an introduction to Wittig himself and his role within the organisation, setting the stage for a broader discussion about Snom's strategic priorities and market focus. From there, the interview delves into the company's background—its evolution from a VoIP pioneer to a provider of integrated communication solutions spanning desk phones, DECT systems, and wireless audio applications.



Oliver Wittig, DECT Product & Professional Services Manager at Snom.

Why DECT still matters

A central theme throughout the discussion is Snom's long-standing advocacy for DECT technology. Wittig explains why the company has continued to invest in DECT even as alternative wireless technologies have gained prominence. For Snom, the advantages are clear: predictable performance, secure communication, and operation in a dedicated, license-free spectrum. These characteristics make DECT particularly well-suited to enterprise environments where reliability is critical and where Wi-Fi networks may already be heavily burdened.



The interview also provides an overview of Snom's current DECT portfolio, highlighting how the company is addressing a wide range of use cases—from traditional cordless telephony to more advanced applications involving mobility, messaging, and integration with unified communications platforms. As Wittig notes, the evolution of enterprise communication is driving demand for endpoints that are not only robust but also flexible enough to integrate into broader workflows and systems.

Innovation spotlight: beaconing

One of the more innovative areas discussed is Snom's work in beaconing technology. Over the past few years, beacon-based solutions have gained traction in sectors such as healthcare, logistics, and retail, where location awareness and asset tracking can deliver significant operational benefits. Snom's approach, centred around the M9B Beacon Gateway and M9T beacon tags, introduces a hybrid model in which Bluetooth-based beacons are integrated with a DECT infrastructure. By connecting the M9B to the M900 base station via a DECT data link, Snom is able to combine the low-power advantages of Bluetooth with the reliability and coverage of DECT.

Wittig shares the thinking behind this development, explaining how customer requirements - particularly around indoor positioning and asset visibility—drove the need for a solution that could scale while maintaining performance. This naturally leads into a discussion of



Snom M9B Gateway integrates professional location and asset tracking and alarm systems into any existing Snom DECT multi-cell system.

scalability, with the interview addressing how many tags can be supported in a typical deployment and how the system performs as it grows. For developers and integrators, these insights provide valuable guidance on how such a solution might be architected in real-world scenarios.

Use cases for the M9B are explored in some depth, with particular attention given to environments such as healthcare and factory environments where accurate, real-time location data can improve efficiency or safety.

Interoperability with Bluetooth ecosystems

Interoperability is another key topic. Given the widespread adoption of Bluetooth Low Energy and established beacon standards such as iBeacon, AltBeacon, and Eddystone, questions naturally arise as to how Snom's solutions fit within this broader ecosystem. The discussion clarifies how the M900, M9B, and M9T coexist with these standards, and what this means for integration with existing platforms and applications. For organisations already invested in Bluetooth-based solutions, this is a particularly relevant consideration.

Market readiness and deployment status

The conversation also touches on product maturity and market readiness. As Wittig explains, these solutions are not merely conceptual – they are already being deployed in live environments, with feedback from early adopters helping to refine and enhance the offering. This real-world validation is an important factor for companies considering adoption, particularly in sectors where reliability and support are paramount.

Looking to the future, the interview concludes with a confirmation that Snom is actively researching the potential for DECT NR+ in its product portfolio, and a broader reflection on the role of the DECT Forum and the importance of industry collaboration. For Snom, active participation in this ecosystem is not just about influence—it is about ensuring that the technology continues to evolve in ways that meet the needs of the market.

Watch the full interview here and at our YouTube channel

For readers working in the development of wireless technologies for Unified Communications and Professional Audio, this interview offers a concise yet insightful overview of both Snom's strategy and the wider trajectory of DECT. It highlights how established technologies can be reimaged to address new challenges, and how collaboration across the ecosystem remains essential to driving progress.

Click on the movie screen below to watch the full video. You will hear directly from Oliver Wittig and gain a deeper understanding of how Snom is shaping the future of DECT-enabled communications.

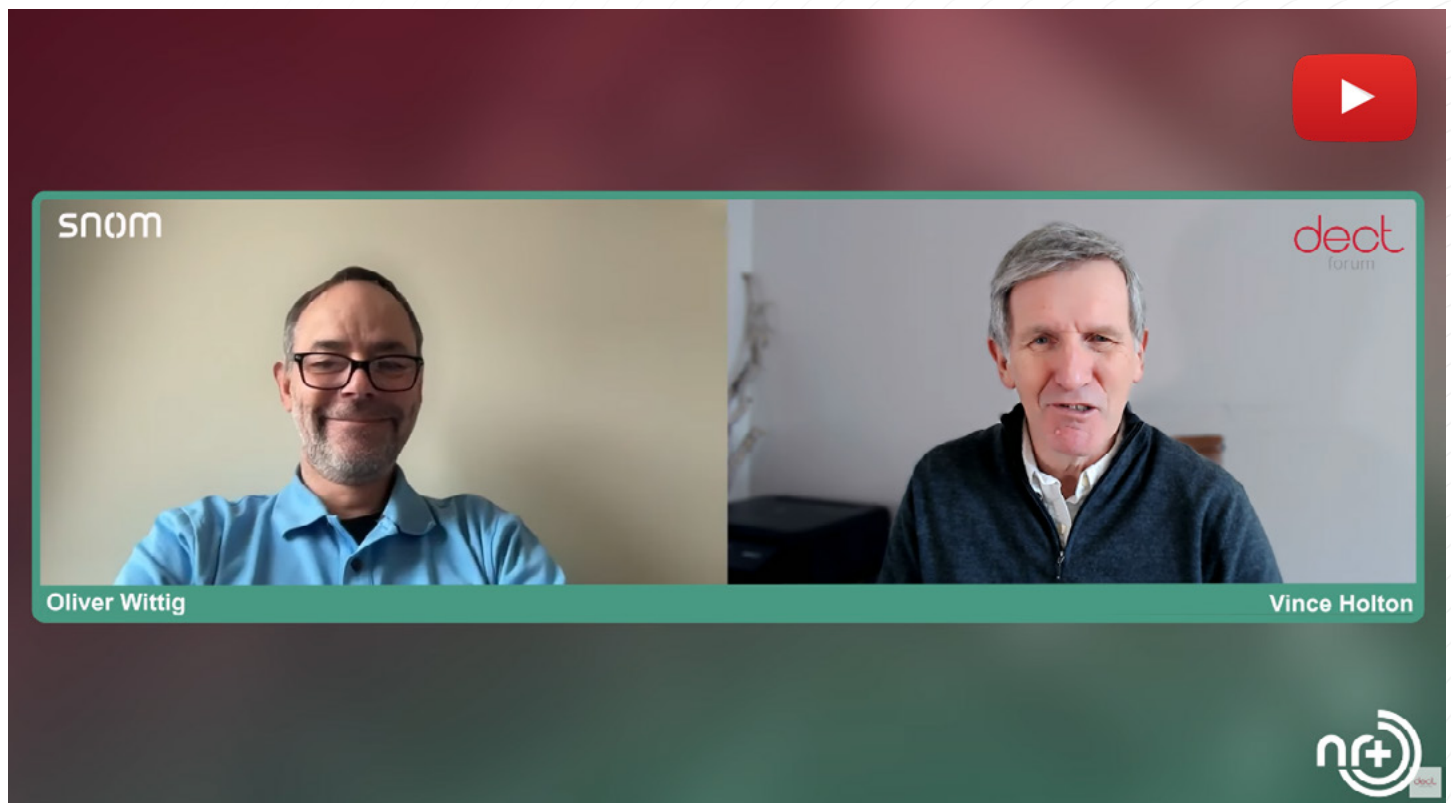



Old traditions combined with modern teaching facilities



The client

Founded in 1495, the University of Aberdeen is a state university in Aberdeen, UK, with about 14.000 students. It offers more than 550 Bachelor's and 110 Master's degree programs.

The challenge

The University of Aberdeen sought a reliable, high-quality microphone solution that could be quickly deployed and seamlessly integrated into their existing audio-visual setups across multiple locations. With the need for clear audio performance in radio frequency-saturated environments, they required a system that would maintain consistent quality while being user-friendly and future-proof with regular software updates.



The solution

After evaluating various options, the university chose the SpeechLine Digital Wireless microphone system, a DECT-based product that addressed their needs perfectly. With SpeechLine, the university now benefits from enhanced audio clarity and reliability, while the system's ease of use and regular updates ensure a future-proof solution that continues to meet evolving needs. The result has been a streamlined, high-performance audio setup that seamlessly supports the university's diverse AV requirements across various locations.

Colin Wylie, Audio Visual Technician, University of Aberdeen commented:

“We decided to go for the SpeechLine Digital Wireless microphone system because it is a high-quality new product from a trusted manufacturer. It filled a gaping hole in our microphone offering within multiple locations. The product is fast to deploy and easy to integrate into existing setups. In radio frequency-saturated areas, the microphones perform very well. All expectations are fully met, and the product is kept well up to date with software updates.”



IT-optimised wireless microphone system for speech & lectures

SpeechLine Digital Wireless is a digital wireless microphone system for speech and lectures, designed and optimized for university and corporate use. Thanks to its broad product portfolio, the system is particularly versatile and can be adapted to the requirements of multiple professional speaking applications. Sennheiser's goal was to make the daily work of IT and AV managers easier and, with the addition of the SpeechLine Multi-Channel Receiver, SpeechLine Digital Wireless presents the perfect audio solution for IT integration.

SpeechLine Digital Wireless operates in the license free DECT 1.9 GHz frequency band and, with the free Sennheiser Control Cockpit platform to manage your Sennheiser systems, opens the door to scalable, network-enabled workflows. With centralised monitoring and control via SCC, users gain full visibility of their entire SpeechLine Digital Wireless system—enabling more efficient operation, proactive maintenance, and significantly reduced servicing effort.

www.sennheiser.com

Updates from the Regulatory Working Group

The following updates were provided by Martin Brock of Shure and Vaughan John of Sennheiser. Both are contributors to the DECT Forum's Regulatory Working Group, which addresses all regulatory issues pertaining to the use and protection of DECT spectrum worldwide.

ITU World Radiocommunication Conference 2027 (WRC-27)

World Radiocommunication Conferences (WRC) are held every three to four years to review, and, if necessary, revise the Radio Regulations, the international treaty governing the use of the radio-frequency spectrum and the geostationary-satellite and non-geostationary-satellite orbits. Revisions are made on the basis of an agenda determined by the ITU Council, which takes into account recommendations made by previous world radiocommunication conferences.

WRC-27 contains several agenda items relating to additional spectrum allocations for the mobile satellite services for both space-to-Earth and Earth-to-space transmissions. Several agenda items, most notably agenda item 1.12, are looking at the 1880-1920 MHz frequency range as a candidate band for these new allocations to the mobile satellite service. Preparation work relating to this agenda item is taking place in Working Party 4C of the ITU-R.

The DECT Forum recently extended its Sector Membership of the ITU-R to include Working Party 4C, which provides it with greater access rights and has permitted the DECT Forum to contribute findings from compatibility studies which show that Earth-based user terminals need to be greater than 2.5 km from a DECT receiver to protect indoor DECT use, and 5 km to protect outdoor DECT use. This presents a significant interference risk to DECT users. The DECT Forum also commissioned a study that shows similar separation distances are needed to protect DECT in various use case scenarios.

The work plan indicates that the report on sharing and compatibility studies is to be completed at the Autumn 2026 meeting. Companies operating in the DECT industry are encouraged to contact their national spectrum regulators to express their concerns on the risks to established DECT use and request that they (the national spectrum regulators) oppose a new allocation of spectrum used by DECT to the mobile satellite service.

Electronic Communications Committee

The Electronic Communications Committee (ECC) brings together 46 countries to develop common policies and regulations in electronic communications and related applications for Europe, and to provide the focal point for



information on spectrum use. Its primary objective is to harmonise the efficient use of the radio spectrum, satellite orbits and numbering resources across Europe. It takes an active role at the international level, preparing common European proposals to represent European interests in the ITU and other international organisations.

The DECT Forum Regulatory Working Group continues to play an active part in the Project Teams assigned by the ECC to address items of work in spectrum bands of interest to DECT.

3.8-4.2 GHz band

On 2nd December 2025, the European Commission announced its Decision to harmonise the use of the 3.8-4.2 GHz band for local, private broadband connectivity for industry verticals across the European Union.

The Decision expressly mentions DECT-2020 NR (see its Recital 11) and the DECT Forum remains closely involved with the development of various regulatory instruments to promote DECT-2020 NR (known as NR+) within this band. The ECC work will continue into 2026.

1910-1920 MHz

The ECC, via Working Group Frequency Management, has recently agreed to add the 1910-1920 MHz band to ERC Recommendation 70-03 which will allow for the use of DECT in this band. The conditions of use are:

- Frequency band: 1910-1920 MHz
- Power: 20 dBm e.i.r.p.
- Spectrum access: Transmit Power Control (TPC) and a scan-based channel selection procedure are required
- Occupied bandwidth: ≤ 3.5 MHz

The DECT Forum recently submitted its response to the Public Consultation stage, and it is hoped that the changes will be reflected in an update of the Recommendation this Summer.

If you would like to learn more about the activities of the various DECT Forum working groups, and perhaps to join one of them in order to contribute to the development of the DECT family of standards, please follow this link:

<https://www.dect.org/working-groups/>

Join the DECT conversation - wherever you are in the world

At the DECT Forum, we're building a truly connected global community around DECT technology - bringing together innovators, manufacturers, and industry leaders to shape the future of wireless connectivity.

As our ecosystem continues to grow with DECT NR+ and expands into areas such as the Internet of Things (IoT), Industrial IoT, and Professional Audio, staying connected has never been more valuable.

Our social media channels are where this community comes to life. They're the place to discover the

latest developments, explore real-world use cases, and engage with insights from across our international member network.

Follow us on LinkedIn and YouTube to keep up with industry news, product innovation, event highlights, and thought leadership from across the DECT landscape.

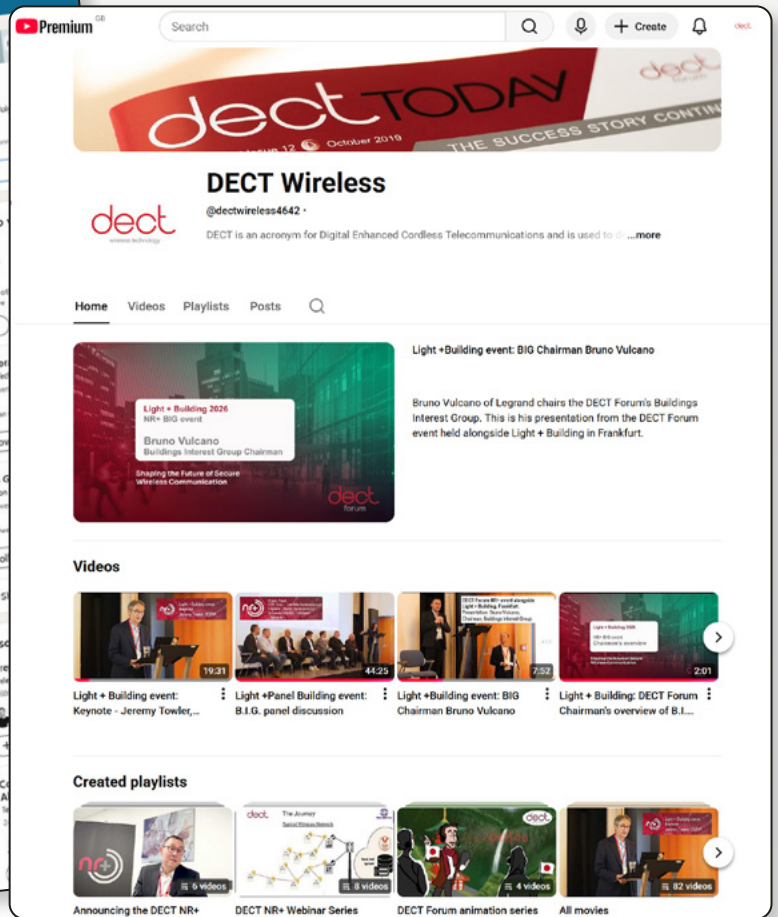
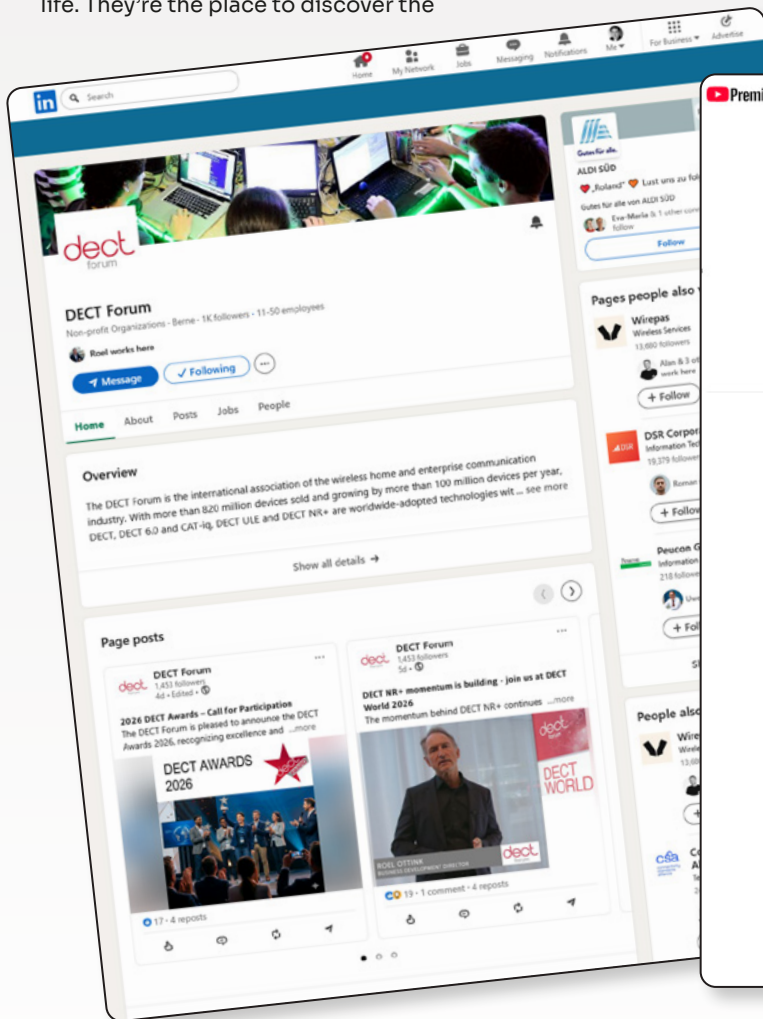

Explore our channels:



LinkedIn:
DECT Forum Group



YouTube:
DECT Wireless

Share your story with us

Got something to share? Whether it's a new product, video, event, or industry perspective, we want to hear from you. By contributing your content, you become part of a wider conversation—and we'll help amplify your message across the DECT Forum's global platforms.

Together, we can strengthen the visibility of DECT technology, unlock new opportunities across emerging sectors, and build meaningful connections within a rapidly evolving ecosystem.

DECT WORLD 2026 – A conference & exhibition shaping the future of DECT & NR+

The DECT Forum invites engineers, product managers, technology strategists, and business leaders from across the wireless communications industry to converge on Munich for two intensive days of innovation, collaboration, and real-world technology insights. DECT World 2026 is the premier annual gathering for everyone who designs, deploys, or builds upon DECT and NR+ technology.

“Two days that define the direction of DECT and NR+ for the year ahead – and beyond.”



WHY DECT WORLD MATTERS

Since its inception, DECT World has been the heartbeat of the DECT ecosystem – the place where the community gathers to take stock of where the technology stands, where it is headed, and how the industry can move faster together. In 2026, with NR+ entering a decisive phase of commercial deployment and new application domains opening up, the conference is more relevant than ever.

Whether you are a chipset vendor, a handset or base-station manufacturer, a software stack provider, an integrator, or an end-user organisation driving digital transformation through wireless voice and data, DECT World 2026 offers direct access to the people and insights that shape the standard.

PROGRAMME HIGHLIGHTS

The 2026 agenda brings together eight major tracks across two days:

- **NR+ Certification Program**
The latest developments in interoperability testing and certification — ensuring NR+ products work flawlessly across the ecosystem.
- **NR+ Ecosystem Update**
A comprehensive overview of ecosystem progress and market momentum, with data on deployments and pipeline.
- **NR+ Stack Availability**
How the latest software stacks are accelerating time-to-market and reducing integration complexity for device makers.
- **NR+ & Pro Audio**
Exploring the convergence of NR+ with Professional Audio applications — updates on standards, latency, and audio quality.
- **New Interest Groups**
Launch and first sessions of two new DECT Forum Interest Groups: Industrial Applications and Pro-Audio.
- **NR+ Hackathon**
An interactive, hands-on development challenge giving participants direct experience building with NR+ technology.
- **Live Demos & Showcases**
Exhibition floor demonstrations from leading vendors — see the technology in action and engage with product teams.

HIGH-LEVEL NETWORKING

Beyond the formal sessions, DECT World 2026 is structured to maximise the value of every interaction. Planned networking breaks, a dedicated exhibition floor, and evening networking event at the Hotel Eurostars Grand Central provide the ideal environment for substantive conversations with peers, partners, and potential customers.



VENUE

Munich continues to be the natural home for DECT World. The Hotel Eurostars Grand Central, located at Arnulfstrasse 35, places delegates in the heart of one of Europe's great technology and business cities, minutes from Munich Central Station and with excellent international air connections.

AT A GLANCE

Event	DECT World 2026 – Conference & Exhibition
Dates	3 – 4 November 2026
Venue	Hotel Eurostars Grand Central, Arnulfstr. 35, 80636 Munich, Germany
Organised by	DECT Forum
Registration	Open now — secure your place at dect-world.org

Registration is now open

Delegate places are limited. Reserve yours today. <https://www.dect.org/events/dect-world-2026/>

“We look forward to welcoming you in Munich.”

Christian Schepke,
Chairman, DECT Forum



Why it is important to be at DECT World.

Click the movie screen from last year's event to watch Schneider Electric's Ben Eatts sum up why it is important to attend DECT World.



dect TODAY

Video enabled issue 25  Summer 2026

dect
forum



DECT Today provides commercial and promotional opportunities in the DECT, NR+, CAT-iq and ULE sectors.

Contact: Roland Schmidt

Email: secretariat@dect.org

Telephone: +49 89 5166 2456

www.dect.org



[Click here](#)



[Click here](#)